

A

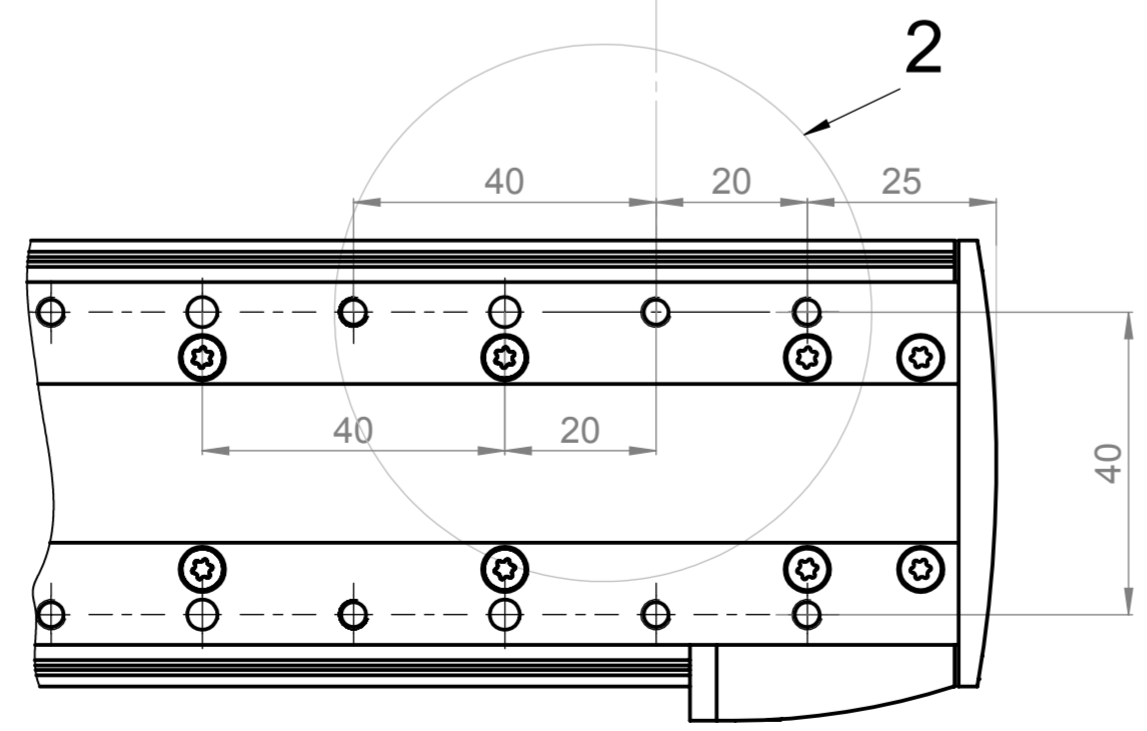

SCHNITT A-A

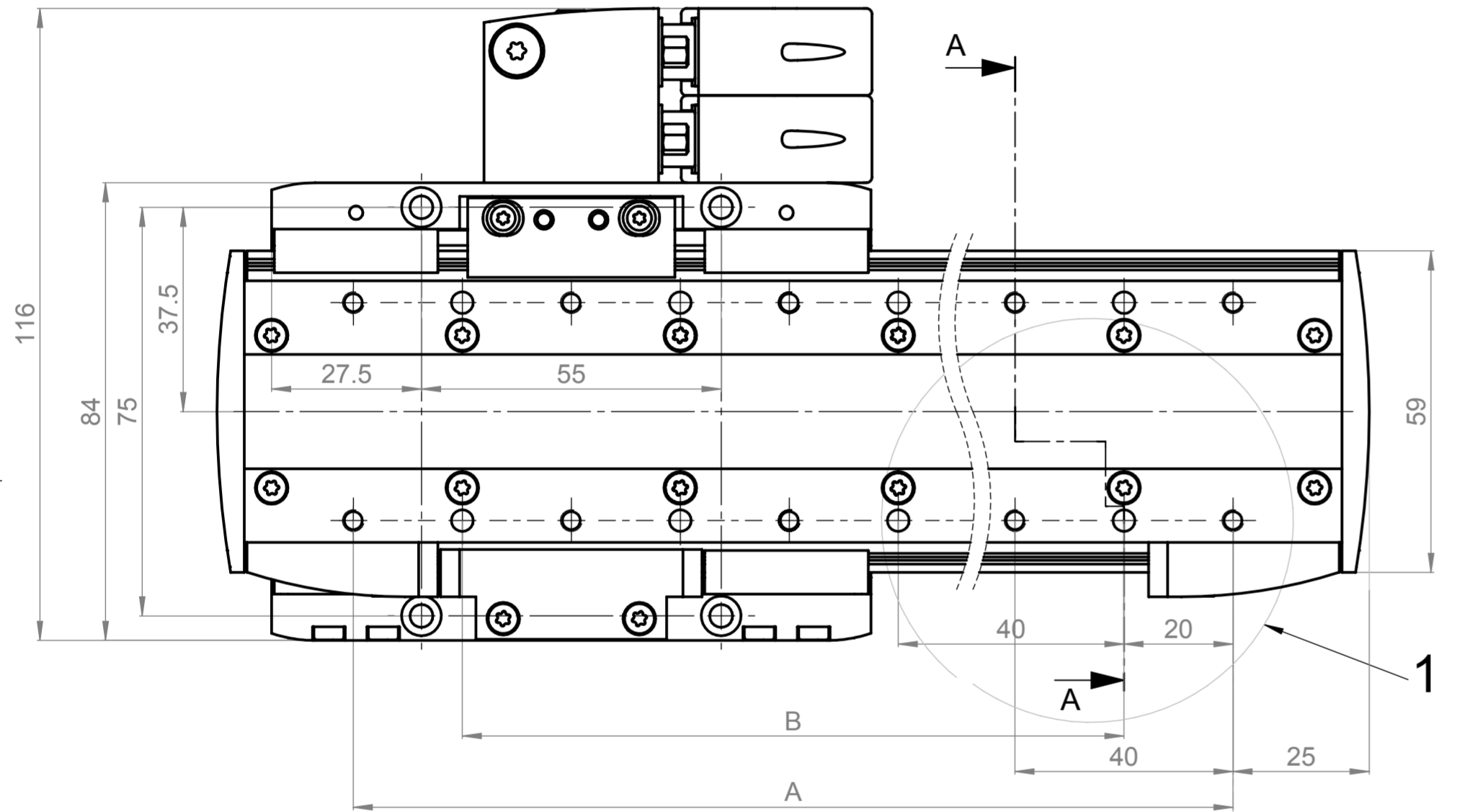
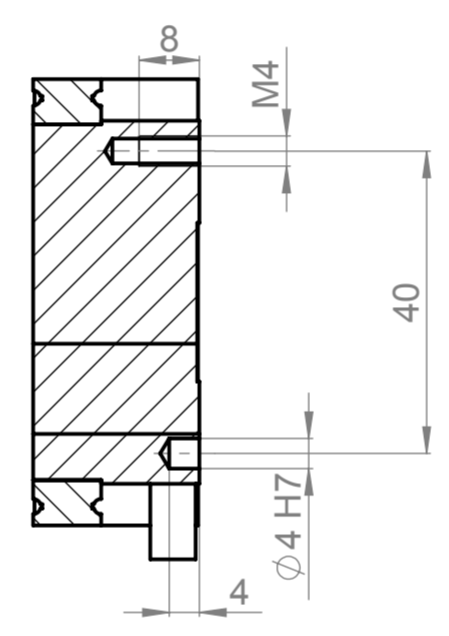

Ansicht A

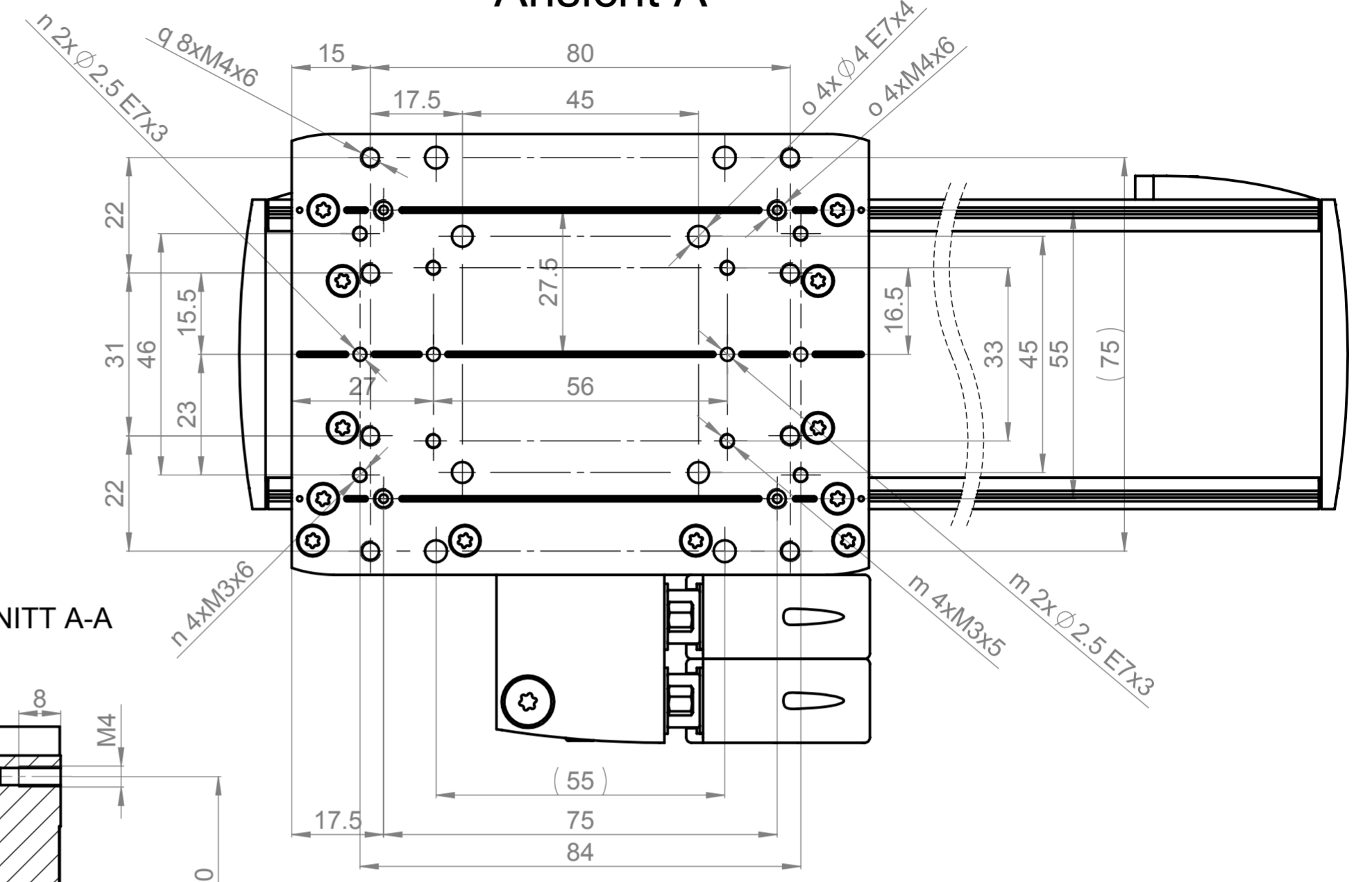

Modell	Hub	L	Typ	B	A
Lxu 40	40mm	170mm	2	40	80
Lxu 80	80mm	210mm	1	120	160
Lxu 160	160mm	290mm	1	200	240
Lxu 240	240mm	370mm	1	280	320
Lxu 320	320mm	450mm	1	360	400

Bohrbild	
Variable	Bohrungen für:
m	Kreuztisch mit Lxc F10
n	Kreuztisch mit Lxc F40
o	Ausleger mit Lxu Schlitten Rücken an Rücken
q	Portal mit Stirnflansch Lxu